

# IMMEDIATE ASSISTANT AND REMOTE MONITORING FOR HOME ALONE ELDERLY PERSONS

Kaviarasan.S<sup>1</sup>, Appas.J<sup>2</sup>

<sup>1</sup>UG Scholar, Dept. of EEE., V.R.S College of Engineering & Technology, Villupuram,  
Tamilnadu, India,

<sup>2</sup>UG Scholar, Dept. of EEE., V.R.S College of Engineering & Technology, Villupuram,  
Tamilnadu, India.

## ABSTRACT:

This paper describes, to monitor the signals of ECG, Body temperature, Heart rate are measured and given to ARM controller. Through GSM/GPRS modem updated parameters are sending directly to the doctor's mobile phone/nearby hospital web portal doctor can also query about the human health through GSM by SMS. In addition to that if elderly people need to operate any electrical devices, can help them by providing RF Remote control. At abnormal conditions buzzer or voice message will alert the disabled and elderly person. When the fall is detected GSM (Global System for Mobile communication) modem transmits these events to the mobile phones of care takers/ relatives of the fallen human. This alert message helps to provide immediate assistance and treatment.

**Keywords:** ARM controllers; Human fall detection; Heart rate; Body Temperature; Abnormal conditions; controlling electrical appliances

## 1. INTRODUCTION

In worldwide Disable and Elderly people can't do their work in day to day life they need some other co worker to taken care by them. If they need to be alone in home may cause any critical or emergency situation depends upon their body condition, so their body conditions should be monitored with high importance as periodically to save them from critical situation if occurs. This system of "Immediate Assistant and Remote Monitoring for Home Alone Elderly Persons" helps them to take care by monitoring by themselves. This system monitor the signals of Body temperature, blood pressure, body temperature, Heart beat pulse rate, position of the patient are monitored for every 20 minutes sending through GSM Modem to doctor's mobile phone/hospital web portal is proposed rescue system for disabled and elderly person. If the parameters goes beyond the threshold value or abnormal conditions buzzer or voice message will alert the disabled and elderly person to assist them immediately. If the patient has fall down in home the MEMS sensor monitor the position of the patient through GSM modem transmits these events to the mobile phones of care takers/ relatives of the fallen human. This alert helps them to provide immediate assistance and treatment. If Doctor suddenly wants to know about the human health of the patient he can also query through GSM by SMS. Main objective of this proposed system is to design a system for patients/impaired people health monitoring system and home automation system for disabled person with the assistance through GSM and RF communication protocols.

## 2. RELATED WORK

In [2] Wireless technology is used and the vital signals are send through PDA and Bluetooth technology. In this there are many disadvantages which are implemented for home alone elderly and

disabled person. Need to take more care on the patients from disaster. In [3] the main drawback of Real Time processing of ECG signal from patients by mobile embedded monitoring stations has been discussed and it is mainly focussed on parsing and two possible solutions from ECG device by Bluetooth to mobile stations. They were mainly discussed only on the ECG but not on the other vital signals of the patient. In [4]. In [5] The paper deals with design a new electronic stethoscope by considering the advantages of both the acoustic and electronic stethoscopes and overall to study the study was performed to evaluate the advantages and limitations of 3 acoustic stethoscopes and 3 electronic stethoscopes. In [6] the human action detections with acceleration sensors have been introduced for disabled and elderly persons who need a help during emergency condition. The concept of acceleration sensor has been study and added in this paper. In [7] and [8] respectively deals with the mobile network and the paper presents Bluetooth transmission module and finally a displaying module (mobile devices). Information is sent via TCP\IP Protocol (GPRS) to a database server containing clinical data, which can be accessed through a web application.

### 3. SYSTEM MODEL

#### A. Existing System

There is only human fall detection or single parameter is monitored and discussed in single papers. Almost more than three parameters are not measured with emergency assistance has not discussed yet now. There is no remote controlling human appliances, no auto assistance. Doctor cannot query about the human health of the patient.

Limitations: Coverage range is limited, Maintenance is very difficult, only one parameter is measured, Monitoring has not taken to next stage, and immediate action has not been taken in existing system

#### B. Proposed System

This system monitor the signals of Body temperature, blood pressure, body temperature, Heart beat pulse rate, position of the patient are monitored for every 20 minutes sending through GSM Modem to doctor's mobile phone/hospital web portal is proposed rescue system for disabled and elderly person. If the parameters goes beyond the threshold value or abnormal conditions buzzer or voice message will alert the disabled and elderly person to assist them immediately this system also available with remote controlled appliances, human monitoring system & well-wishers acknowledgement. RF communication implemented to control the household appliances. GSM modem available to send the current status of human health. Doctor can also query about the human health through GSM by SMS. If the patient has fell down in home the MEMS sensor monitor the position of the patient through GSM modem transmits these events to the mobile phones of care takers/ relatives of the fallen human. This alert helps them to provide immediate assistance and treatment

Merits: Parameters are updated directly to the web portal, Indicates buzzer and voice message during abnormal condition, controlling the electrical devices using RFID, Time efficient, highly portable, Doctor can also query about the human health through GSM by SMS

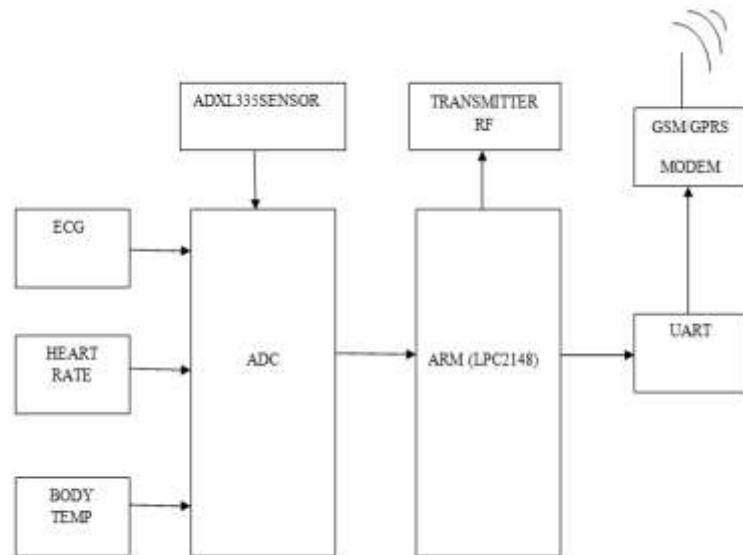

**Fig.1. Block Diagram for proposed system**

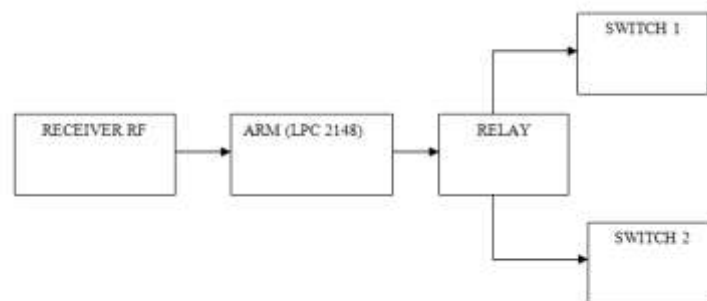

**Fig.2. Remote control**

### C. ARM LPC 2148

ARM generally known as Advanced RISC Machine is a reduced instruction set computer (RISC) instruction set architecture (ISA) developed by British company ARM Holdings. The ARM architecture is the most widely used 32-bit instruction set instruction. LPC2141/42/44/46/48 microcontrollers are based on a 16-bit/32-bit ARM7. But in this system we use LPC 2148 with high speed flash memory ranging from 32 to 512 KB .It has more number of pins when compare to PIC Microcontroller. Here ARM has 64 pins but in PIC it has only 40 pins. In ARM LPC 2148 it has various 32-bit timers, single or dual 10-bit ADC(s)(more number of sensor can be connected to ADC), 2 UART, 2 SPI, 2 I2C protocol, 10-bit DAC, PWM channels (6 channels) and 45 fast GPIO lines with up to nine edge or level sensitive external interrupt pins make these microcontrollers suitable for industrial control and medical systems. 128-bit wide interface/accelerator enables high-speed 60 MHz operation. InsystemProgramming/In-Application Programming (ISP/IAP) via on-chip boot loader software. When compare to PIC, ARM has more

advantage to this system so, I have used ARM microcontroller for “Immediate Assistant and Remote Monitoring for Home Alone Elderly Persons”.

#### D. Temperature sensor

The Disabled and elderly person body temperature is important to monitor so, here we use LM35 temperature sensor to monitor. It is generally to be accepted that normal body temperature ranges between 36.1C (97F) to 37.2C (99F) is normal if it abnormal temperature over 100.4°F. If temperature is abnormal (high) it indicates by buzzer and also sends message to nearby hospital web portal as well to doctor’s mobile phone. LM35 does not require any external calibration or trimming to provide typical accuracies of  $\pm 1/4^\circ\text{C}$  at room temperature and  $\pm 3/4^\circ\text{C}$  over a full  $-55$  to  $+150^\circ\text{C}$  temperature range. Since we are using the ADC in 10 bit mode with a reference voltage of 5V supplied externally, the maximum ADC value can be 1023 and minimum can be 0.

**Features of LM35:** Low cost, low output impedance, linear output, very low self-heating, less than  $0.1^\circ\text{C}$  in still air. Calibrated directly in  $^\circ\text{Celsius}$  (Centigrade), linear  $+ 10.0 \text{ mV}/^\circ\text{C}$  scale factor,  $0.5^\circ\text{C}$  accuracy guaranteeable (at  $+25^\circ\text{C}$ ), Rated for full  $-55^\circ$  to  $+150^\circ\text{C}$  range, suitable for remote applications, low cost due to wafer-level edge.

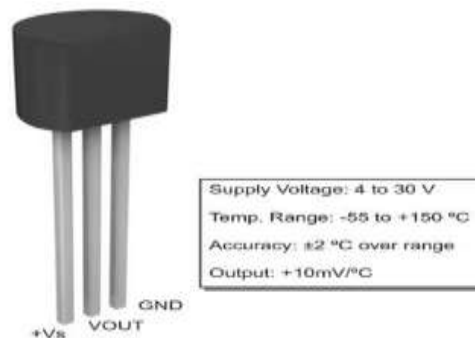
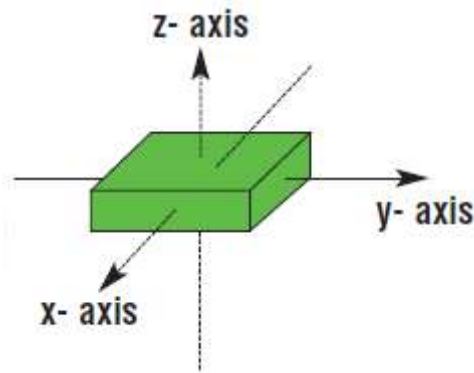

Fig.3. Pin Details of LM35 Temperature sensor

#### E. MEMS 3-AXIS ACCELEROMETER

Microelectromechanical systems or MEMS are integrated micro devices or systems combining electrical and mechanical components they are fabricated using integrated circuit(IC). We use 3-axis Accelerometer, using state of MEMS technology. This small and highly sensitive accelerometer can detect acceleration, inclination and vibration by measuring the motion in all the three x-axis, y-axis, and z-axis simultaneously. In this Helper monitoring system let us assume the threshold value is 1.5V. If the voltage level gets increases above its threshold value X-axis used to sense the value. If it gets decreases beyond the threshold value Y-axis used to sense and Z axis in all the positions and directions simultaneously.



**Fig.3. Three-axis direction of MEMS accelerometer**

The MEMS 3-axis accelerometer consists of a Mass at the centre of the sensor's chip, which is balanced by 4 Beams doped with Piezoresistive material. When the sensor is used to acceleration in any direction, the movement of the mass causes the 4 Beams to collapse and so change the resistance in the piezo material. This enables the sensor to detect the acceleration motion. Here in this model ADXL335 accelerometer is used. It is small, low power, complete 3-axis accelerometer with signal conditioning voltage outputs. The product measures acceleration with a minimum full-scale range of  $\pm 3$  g. It can measure the static acceleration of gravity in tilt-sensing applications, as well as dynamic acceleration resulting from motion, shock, or vibration. The user selects the bandwidth of the accelerometer using the CX, CY, and CZ capacitors at the XOUT, YOUT, and ZOUT pins. Bandwidths can be selected to suit the application, with a range of 0.5 Hz to 1600 Hz for the X and Y axes, and a range of 0.5 Hz to 550 Hz for the Z axis. Features of MEMS sensor: Selectable Sensitivity (1.5g/2g/4g/6g), low Current Consumption: 500  $\mu$ A.

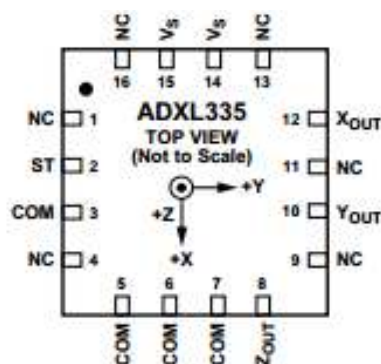

**Fig.4. ADXL 335 Pin Configuration.**

#### F. Heart Beat Sensor with output waveform

This heart beat sensor is designed to give digital output of heart beat when a finger is placed inside on it. The top-most LED flashes in unity with each heart beat. This digital output can be connected to microcontroller directly to measure the Beats Per Minute (BPM) rate. It works on the principle of light modulation by blood flow through finger at each pulse. The sensor consists of a super bright red LED and light detector. The light must pass through finger and detected at other end. With each heart pulse the detector signal varies. This variation is converted to electrical pulse. This signal is amplified and triggered through an amplifier which outputs +5V logic level signal. The output signal is also indicated on top by a LED which blinks on each heart beat. ECG can also be calculated from flow of blood.

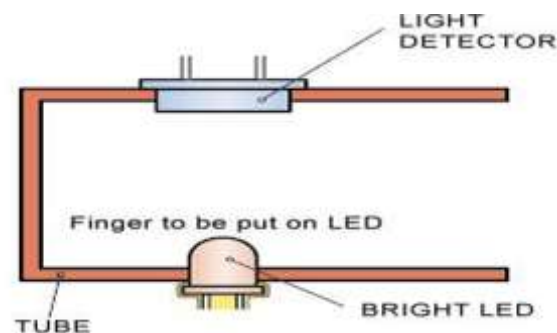

**Fig.5. Sensor Construction.**

**Features:** Heart beat indication by LED, Instant output digital signal for directly connecting microcontroller, Compact Size, Working Voltage +5V DC

**Applications:** Digital Heart Rate monitor, bio-Feedback control of robotics and applications, exercise machines.

### **G. Functioning Of RF Transmitter Module TX3304 and Receiver Module RX3304**

The wireless transmitter module can be used to transmit data at up to 3 KHz from any standard CMOS/TTL source. The module is very simple to operate and offers low current consumption (typ. 11mA). In this module TX1-433.92MHz is used to transmit the data from the protected area. It receives the data from the controller and transmits the data at the frequency of 433.92MHz. The module is very simple to operate, requiring only two connections. The output impedance has been designed to give optimum performance when coupled with a small antenna such as a tuned loop or short whip. The modules are compatible with the AM Receiver modules. The demodulated signal from the receiver module is sent serially to the decoder, the decoder decodes the received digital signal into ten address bits and eight data bits, the address bits compared with the instrument specific address, both address are match then the decoder generates the valid transmission signal to the microcontroller to receive the data.

**Output waveform:**

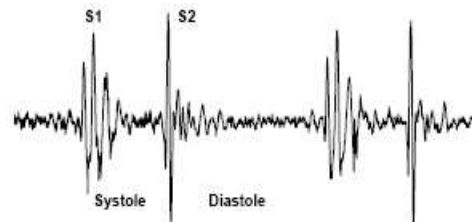

**Fig.6. Heart beat waveform**

The opening and closing of valves in the heart produces sounds during contraction and dilation which is normally audible through a stethoscope. These sounds are rhythmic to heart beat and can be sensed using microphones. Apart from the normal heart sounds (S1 and S2-Lub and Dub), abnormal sounds called murmurs can also be recorded. Normal heart sounds are used to determine the heart rate. The normal heart sounds and different murmurs have different spectral characteristics so with proper filtering the abnormalities of the heart can be visualized. This acoustic property is used in phonocardiographs to determine the heart rate. The above figure shows normal and abnormal heart sounds

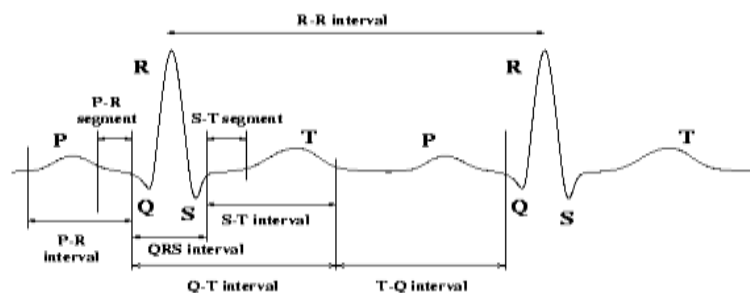

**Fig.7. ECG waveform**

The ECG signal is characterized by six peaks and valleys labelled with successive letters of the alphabet: P, Q, R, S, T, and U. The P-peak is produced by muscle contraction of the atria. The R-peak shows the ending of atrial contraction and the beginning of ventricular contraction. Finally, the T-peak marks the ending of a ventricular contraction. The magnitude of the R-peak normally ranges from 0.1 mV to 1.5 mV. The average heart rate is calculated by first measuring the time interval, denoted RR interval, between two consecutive R peaks and taking the average reciprocal of this value over a fixed window, usually 15, 30 or 60 seconds. This average is then scaled to units of beats per minute (bpm). R-peak is a part of the QRS complex which represents ventricular depolarization

**H.GSM/GPRS Modem**

This Includes SMS functionality enables the sending and receipt of text messages. A common use for this functionality is an SMS server for the automated sending and receipt of bulk text messages. The modem implements the 2403 GSM Engine. This ensures high quality and reliable operation along with compatibility with all standard GSM networks. The unit connects directly to a PC or terminal device via the DB-9 RS232 Cable interface. The integral SIM card holder accepts standard SIM cards. The only other connections required are to dc power supply and Antenna

#### 4. SIMULATION AND HARWARE RESULT

The **Microcontroller Simulation on Proteus Software** and the Output window with monitoring vital signals and MEMS position of the person. When the fall is detected GSM (Global System for Mobile communication) modem transmits these events to the mobile phones of care takers/ relatives of the fallen human. This alert message helps to provide immediate assistance and treatment. The below virtual terminal-GSM represents the temperature and the axis of the patient is displayed as “PATIENT FALL”.

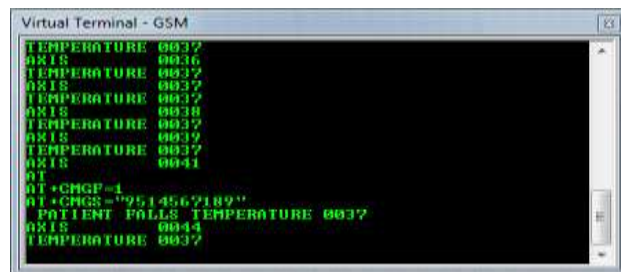

Elderly people need to operate any electrical devices, because the cant move quickly in their home they need assistance ,so that we can help them by providing RF Remote control for controlling home appliances. The below diagram represents first set of two relays OFF Condition and second set of two relays ON Condition of home appliances.

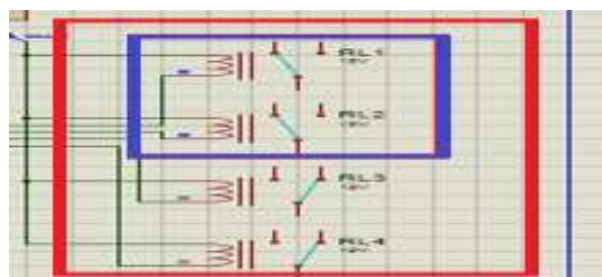

In hardware kit represents a finger is placed inside on the clip. The top-most LED flashes in unity with each heart beat. This digital output can be connected to microcontroller directly to measure the Beats Per Minute (BPM) rate. It works on the principle of light modulation by blood flow through finger at each pulse. The sensor consists of a super bright red LED and light detector. The light must



pass through finger and detected at other end. With each heart pulse the detector signal varies. This variation is converted to electrical pulse.

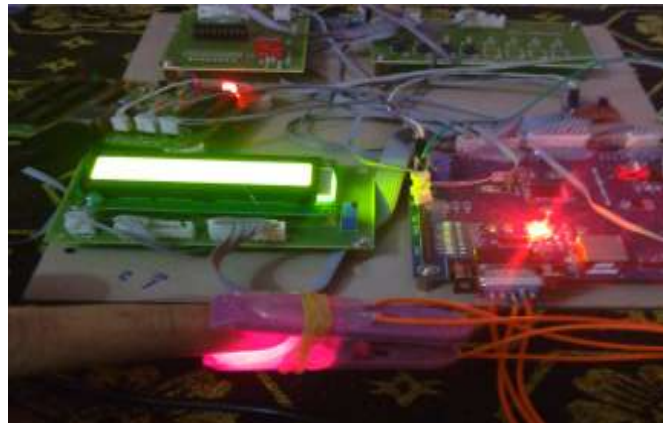

The GSM (Global System for Mobile communication) modem transmits these events to the mobile phones of care takers/ relatives of the fallen human as a message shown as yellow box. This alert message helps to provide immediate assistance and treatment. Temperature, heart rate is displayed in the below output window.

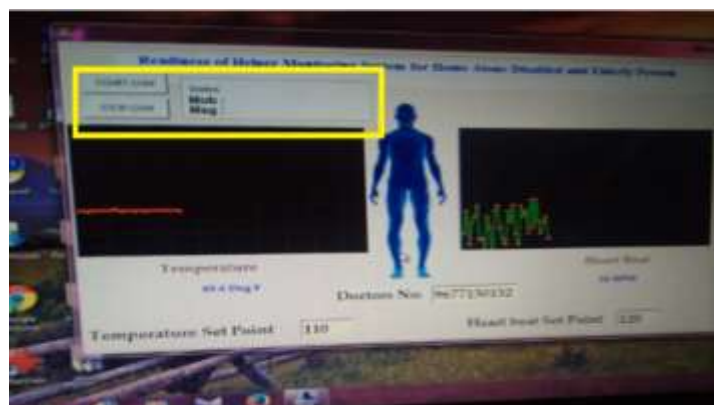

## CONCLUSION AND FUTURE WORK

This Paper includes 3 vital signals to monitor from remote location and send message through GSM to doctors, care takers, as well as doctor can query by sending message to view the monitored parameters. Additionally RF is added to control the home appliances for disable and elderly people and MEMS for monitor the position of the person. In future additionally we may add security for disabled and elderly person from unauthorized person and we may include more vital signal to monitor. This paper is very simple to implement with low cost and we can take this to the next level in wireless sensors protocols as a research area to implement for home alone monitoring system in future.

**REFERENCES.**

1. J. -R. Chang and C.-C. Tai, "A New Wireless-Type Physiological Signal Measuring System Using a PDA and the Bluetooth Technology" IEEE Department of Electrical Engineering, National Cheng Kung University, Tainan, Taiwan, 2006.
2. O. Krejcar, D. Janckulik, L. Motalova and K. Musil, "Real Time Processing of ECG Signal on Mobi Embedded Monitoring Stations," Second International Conference on Computer Engineering and Applications, 2010.
3. Y. M. Lee and M. Voghavemi, "Remot Heart Rate Monitoring System
4. K. Kho, R. Besar, Y. S. Tan, K. H. Tee and K. C. Ong, "Bluetooth enabled ECG Monitoring System," Faculty of Engineering and Technology, Multimedia University (Melaka Campus), Jalan Ayer Keroh Lama, 75450 Melaka, Malaysia, 2005.
5. Grenier MC, Gagnon K, Genest JJ, Durand J, Durand LG, "Clinical comparison of acoustic and electronic stethoscopes and design of a new electronic stethoscope", PubMed, 1998.
6. K.Arai, T.X.Sang, N.T.Uyen, Task allocation model for rescue disable persons in disaster area with help of volunteers, International Journal of Advanced Computer Science and Applications, 3, 7, 96-101, 2012.
7. Jain, N.P. ; Jain, P.N. ; Agarkar, T.P. Information and Communication Technologies (WICT), World Congress on 8..Megalingam, Rajesh Kannan ; Kaimal, D.M. ; Ramesh, M.V, Advances in Mobile Network, Communication and its Applications (MNCAPPS), International Conference of the IEEE, 2012.
8. S. Pavlopoulos, E. Kyriacou, A. Berler, D. Koutsouris, "A mobile system for emergency health care provision via telematics support-AMBULANCE", Information Technology Applications in Biomedicine, 1988