

CONSULTATION SERVICES USING IVR TELEPHONY BASED ON EXPERT SYSTEM PERSPECTIVE

¹J.Sivaguru, ²K. Uvarani, ³T.Sunitha, ⁴A.Shanmuga Priya,

¹Assistant Professor, Dept Of ECE, Ganadipathy Tulsi's Jain Engineering College, Vellore,

^{2,3,4}Research scholar, Dept Of ECE, Ganadipathy Tulsi's Jain Engineering College, Vellore.

Abstract

Now a days the social computerization and automation has been increased and the ATM and credit card has been installed and spread out to simplify the activity for financial activity, the banking activity has been simplified, however the crime related with financial organization has been increased in proportion to the ratio of spread out of automation and devices. Those crimes for the financial organization have been increased gradually from year to year. In this system the sensor at the entry door of the ATM, will restrict the entrance of a single person only. More than one entry into the ATM room , will block the multiple entry. Then the system detects facial feature and decide whether the person is wearing a mask. After authenticating the users card access the authentication procedure for electronic transaction. One time Password (OTP) is send to users mobile after paring ATM and Mobile through bluetooth. Security of one-time password is essential because nowadays most of the transactions are performed with the help of this mechanism. The code received by the customer should be entered by pressing the keys on the touch screen.This is done using Interactive Voice response (IVR)technology.Consultation mechanisms conduct questions and answers by using interactive voice response (IVR) based on expert system approach. A decision tree model is selected to represent the knowledge base of expert system, because it is possible to provide such scenario of interaction. This gives a multilevel structure, where the initial state with the first question runs till the final state as a decision or a conclusion. Furthermore, the knowledge base is mapped into a database that can be accessed by applications. Some fields of database tables contain a location of the voice files. This application will play the question voice files and receive answers of users for each state in its path to reach a decision or conclusion that is played to the user. In accordance with the testing indicated by the monitoring application and experts' justification, the system is able to trace the path in a predetermined interaction consultation.

Keywords: IVR, consultation service, telephone, expert System.

1. INTRODUCTION

IVR telephone service has been widely used, particularly for companies to provide services to their customers. This service is commonly used to replace an operator as an automatic answering machine. The service has become one of the essential part of information because telephone service infrastructure has been widely available in many countries and its use is simpler compared with today's technology like the Internet that requires specialized knowledge .In addition, this information allows the service performed interactive compared dissemination media such as TVs and radios . The existence of the interactive communication features, IVR potential to be developed as consulting services. Many of problems in societies need support solutions that can be done with the consultation approach. But IVR services are still in the context of dissemination of information that is merely directed to specific information. Generally, these services provide a kind of a multilevel menu, and users can follow to navigate towards information that is expected]. On the other hand Consulting services are required to identify facts or symptoms that arise so that it can be done inference or diagnosis on certain conclusions and provide appropriate advice]. This is in

line with the concept of an expert system that is developed in a question-and-answer application. The expert system maps the knowledge of experts in a structured way that allows reasoning to the facts that are identified. Therefore, in this paper we propose an approach that resembles IVR consulting services with the perspective of an expert system.

2. RELATED WORK

Studies on IVR has been undertaken to optimize the services on the menu system. In IVR services developed in the form of personalization that allows users to customize the information services they need. In IVR services developed with adaptive menu. This adaptation is based on users' behavior, so it can save time. This feature is the result of an investigation . In IVR is developed as a dynamic service by providing the features of the service scenario setting, so that service arrangements can be done through configuration without changing the program. Dynamic IVR services to find a set of composed services have been proposed in these services are related to the targeted user QoS and the regulation of business policy constraints that are required by the company. This approach use Fuzzy AHP method for analysis to support the decision. Furthermore, this system is developed in which provides a kind of knowledge base to improve the reasoning in the decision making.

3. ONLINE EXPERT SYSTEM USING DECISION TREE

Expert system is software that works on a computer system In a broad scale, the computer is not only an independent computing machine, but also a computing machine that is accessible by the user from a remote place through a specific interface. Application interface expert system provides a service for users that allows them to interact. This interface is a medium to express the facts that appear in a systematic way and to present the results of reasoning systems. Fig. 1 captures an online expert system interaction model adapted. In the development of expert systems as an on-line service, it uses various media interfaces. As in a web-based expert system, the interface used is the browser application ,whereas for the SMS service the interface uses mobile phones When the service is applied to voice communications services, the interface that can be used is a telephone line. With the online media, the usability of expert system application services will be affordable for users.

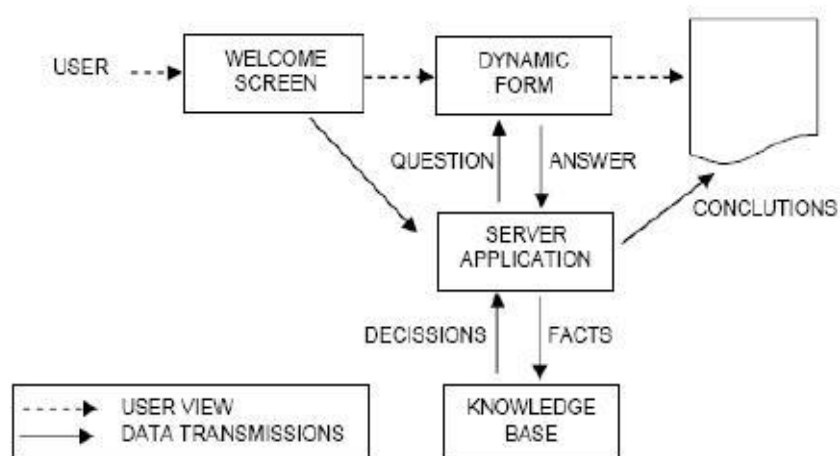

Fig. 1. Model of online Expert System

An Expert system works with reference to the expert knowledge that is mapped in a representation. This representation is called a knowledge base that accommodates the description of the facts and description of the

conclusions, and the availability of the rule base as the basis for reasoning One form of the representations is a decision tree .The decision tree model describes the multilevel structure from the initial state to the final state as a decision or a conclusion. Branches as option would establish the rule that directs the state gradually towards a particular decision. This decision tree is a kind of conceptual model, so it requires a form that can be recognized or accessed by an application program such as a database

4. REPRESENTING DECISION TREE INTO DATABASE

This study employs a decision tree model as a knowledge representation of the developed application. Fig. 2 illustrates that decision tree contains several connected nodes. The nodes have a role based on its category. Nodes that function in the process of identification of facts or symptoms called decision nodes. The decision node in the initial identification is called a root node. Decision node provides branches to the next nodes, so that will be formed paths which ended in leaf nodes. Paths will form a kind of rules that accommodate variations of the decision. A conclusion or diagnosis results obtained from the leaf nodes are usually accompanied by suggestions.

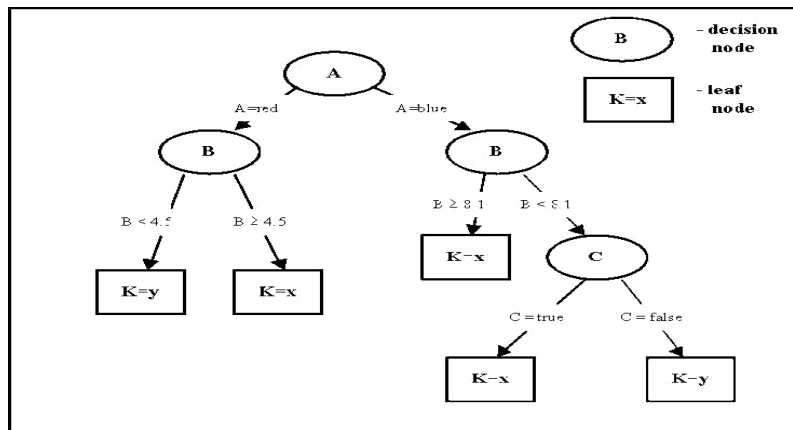

Fig. 2. A decision tree example

In order to provide a knowledge base, which is accessible by applications, the decision tree model must be mapped into a database model. Based on decision tree concepts, there are four elements that are important to be accommodated in a particular database including problem domain definition, facts or symptoms definition, possible conclusion (diagnosis) definition, and rule structure representation that illustrates the relationships between each nodes. Fig. 3 alleges the database design for storing the knowledge base using decision tree approach in accordance with previous work. Several tables in the database above own some functions. Case Table provides a domain scope of a particular problem; Symptom Table stores facts definition as symptoms of possible problem; Diagnose Table accommodates possible conclusions and corresponding suggestions; Rule Table represents a rule base with a decision tree approach.

Some fields are accommodated in the Rule Table. Those fields are IsRootNode field that stores indication data from initial identification to distinguish whether it is a root node or a decision node that exists. Identification_question field holds question data according to symptoms table. Answer_Description field stores options of label data. Answer_Link field holds links to appropriate answers. The links can direct to the next question (decision node) or a conclusion (leaf node). IsAnswerLeafNode field that indicates answer type, whether it is interaction process should continue or not.

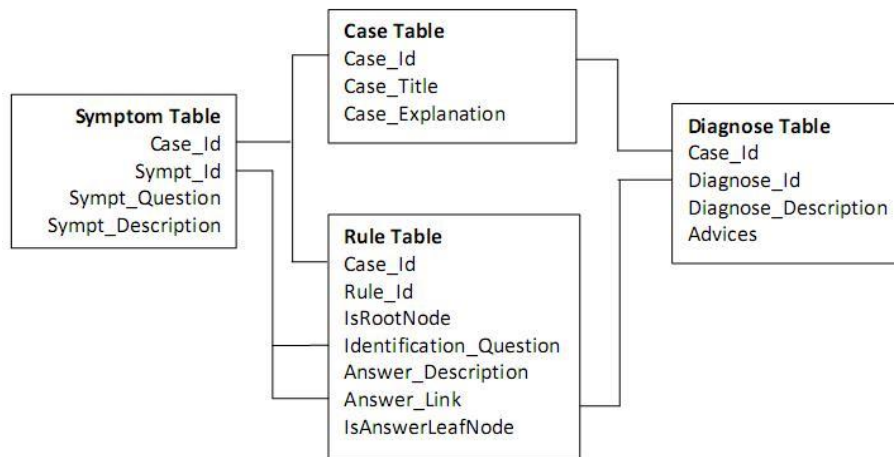

Fig. 3.Database design for storing knowledge base.

In the context of the IVR application, some fields accommodate the voice files to be played. Case_Explanation field serves to store the location of the voice file of the system description. Sympt_ Question field serves to store the location of the voice file of the questions of symptoms identification, and Diagnose_Description field serves to store the location of the voice file of the diagnosis results, and Advices fields to accommodate the location of the voice file of the suggestions will be given.

5. SYSTEM DESIGN

A. System Architecture

The system architecture consists of hardware elements and software elements (Fig. 4). Hardwares are in the forms of server systems that support computing services. This server is connected to telephone interface that connects to telephony system (PBX) . Phone interface plays a role channeling voice messages and detects the code tone (DTMF) sent by the user through the telephone keypads pressed. Users connected to a telephone line can take an advantage of aural consulting services.

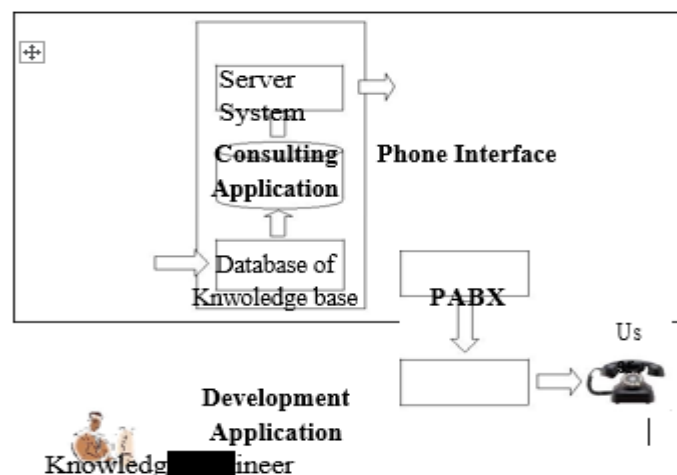

Fig. 4. System Architecture.

Elements of the software system consist of a database representation of the knowledge base, development application, and consulting application. The database serves to accommodate the knowledge of experts in the form of a knowledge base. Application development is a medium for knowledge engineers to manage data representation of knowledge. Consulting application is software that becomes the user interface for the service. This application will work to bring the user to trace a path on decision tree.

B. Tracing Mecanism of Decesion Tree

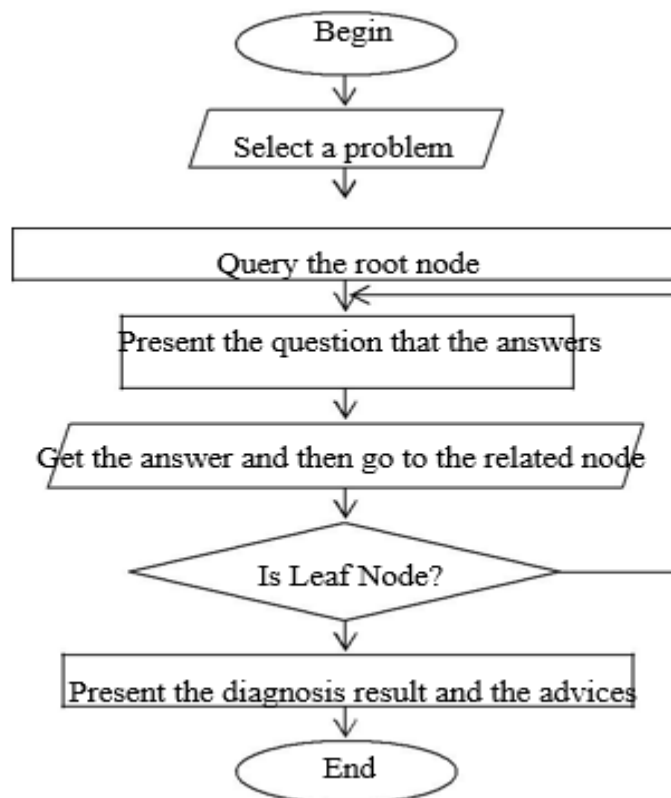

Fig. 5.Mechanism of Decision tree tracing.

The main element of the proposed system is the database, which accommodates the knowledge base models. Knowledge engineer can create or modify data of the knowledge base that is stored in the tables through the interface of the application development. The consultation process can be done after the knowledge base is formed. Then, application consultation expected to be able interpret the knowledge base models. Furthermore, a mechanism is needed so that the interpretation of the consultation process can work as referring in ,as shown in Fig. 5.

In accordance with Fig.5, the consultation process begins after a case is selected. Root node containing the initial question acts as a starting point the identification process of symptoms or facts. The question in the form of the multiple choice answers are links to other nodes. The branches of the answers to these questions are used to determine the next step, whether it is a branch leading to a decision node or leaf node. If the branch is a decision node then show further identification questions were also to determine next steps. But if the branch is life node then show the results

of the diagnosis as well as suggestions. At this point the consultation process ends. Furthermore, the application program can utilize these mechanisms based on the programming language used.

6. DENGUE FEVER SEVERITY CONSULTING CASE

Dengue fever is a disease that has become all over the world attention, as is frequently cause of death. According to WHO, there are more than 900.000 cases in more than 60 countries just between 2000 and 2007. Moreover, dengue fever incidents are continuously monitored through Dengue Map .Certain deaths are mostly because later treatment. Thus, prevention efforts have to be improved. Interactive information preparation (consultative) for this occurrence is necessarily needed for public. An example of this, is online consultation application that employs an expert system. This study refers to a dengue fever example case from WHO regarding dengue fever case classification .Dengue without warning sign is the lowest level. Dengue with warning signs is the upper level, while the severe dengue is the most dangerous. The classification of dengue severity is Each classification has specific symptoms that indicate the diagnosis and proper treatments. According to this reference, the expert system case is aimed as a dengue fever consultation media to identify the disease level and appropriate treatments. Identification process is carried out based on easily known facts from the patients.

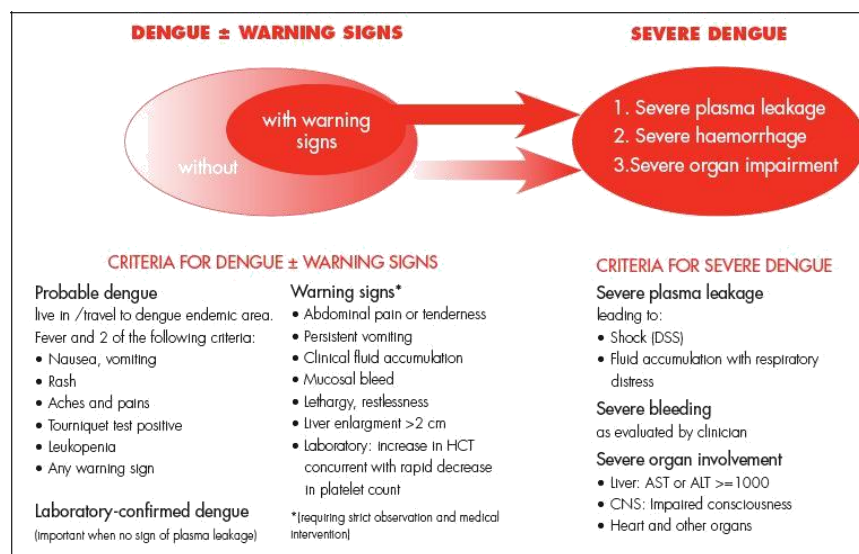

Fig. 6. WHO's classification of dengue based on the severity levels

Fig. 7 illustrates an example of a decision tree of a dengue fever model. This model is developed through consultation and discussion with three physicians, one of them is an internist. The physicians play as experts in this domain problem. The model in the form of decision tree consists of some nodes. Nodes with Q code indicate branch node as question item identification. The questions have yes (Y) or no (N) answer choices that will direct to the next node. In the context of IVR, answer yes or no can be presented by code 1 or 0 from phone keypad. Node with D code is a conclusion in the leaf node.

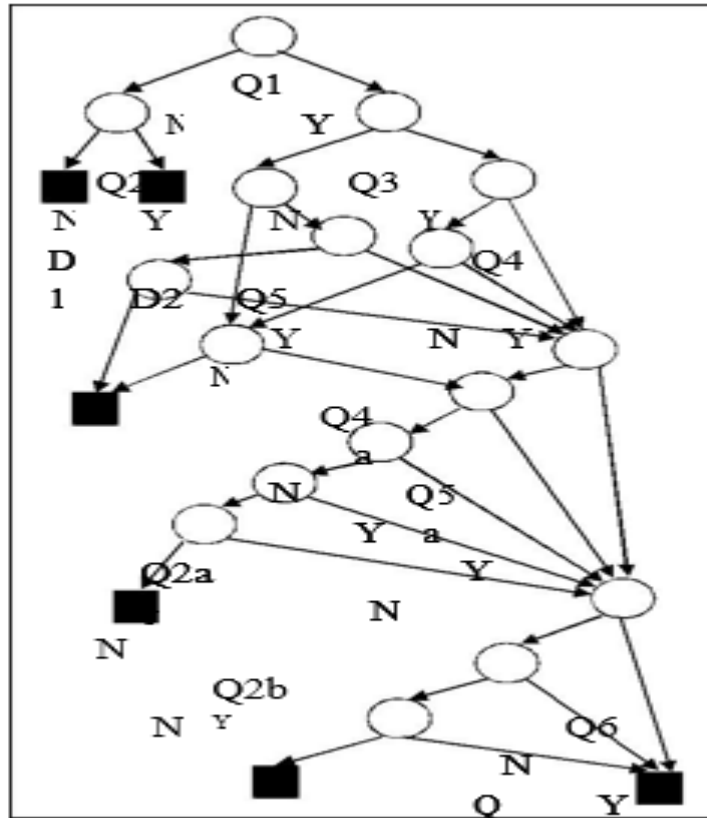

Fig. 7. Example decision tree of Dengue Fever.

This consultation service is tested by referring to a case example that is represented in the decision tree described in Fig. 7. The scenario will lead user to go through this following path: Q1-Q3-Q4-Q6-Q7-Q8- Q9-Q10-D4. Fig 8 and Fig. 9 shows monitoring application during testing.

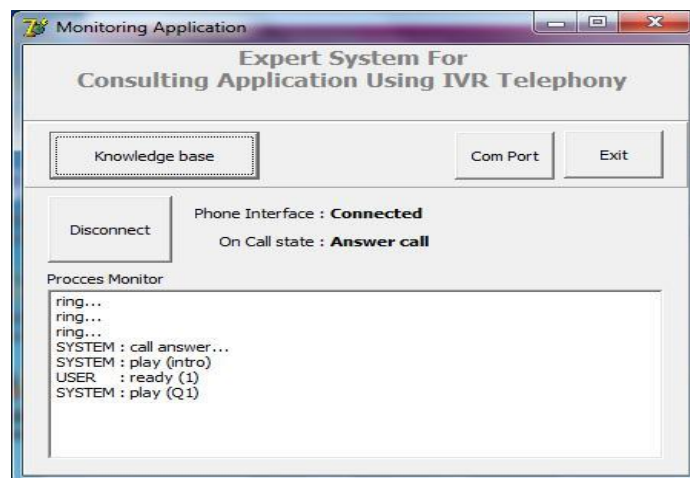

Fig. 8.Beginning consulting proces and first identification question.

Fig 8 illustrates the indication of starting consulting process. A voice of service introduction (Intro) is playing. After the users are ready for the consultation, they should press “1” to begin. A first question (Q1) will play, then users must ask yes/no by pressing keypad code 1/0. This phase will occur for a couple of activities until the last question (Q10) that will lead to reach conclusion (D4) which is shown on Fig. 9.

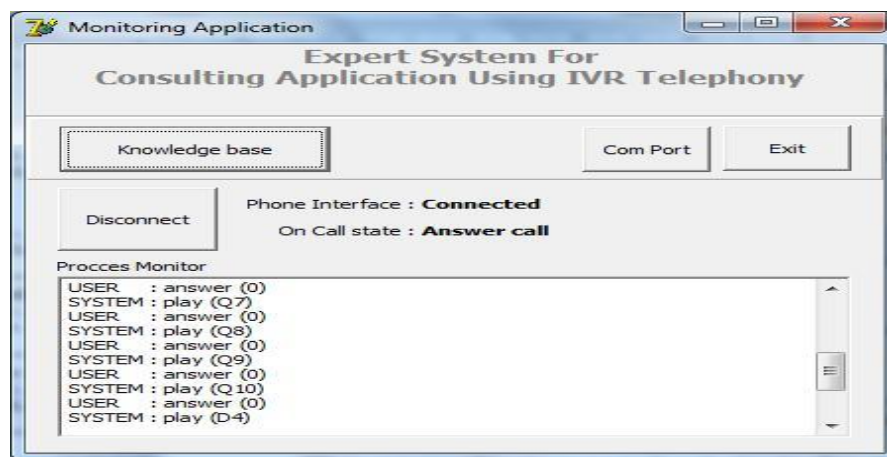

Fig. 9.Final symptom identification (Q10) that will lead to a conclusion(D4)

Testing result illustrates that the interaction mechanism (questions and answers) has worked through the correct path according to the plan. The tests were also conducted on the all paths (123 times). Validation was undertaken during testing by the experts (three physicians) as user representation. The experts agreed with the results of the all tests. The tests show that the application is able to read the data for symptom identification until it reaches a particular conclusion, which is provided by the IVR system according to users’ answers. Thus, the rules that represent a constructed decision tree are able to show the interaction mechanism between machine and user. Finally, the model presented in a decision tree can be implemented in handling other cases.

CONCLUSION

IVR telephony as a voice communication medium allows to be used as consulting services. This service can be developed by an expert system approach that utilizes a decision tree representation. The decision tree will serve to provide path consulting services from initial identification questions towards a particular conclusion interactively. The test results show that the proposed tracking mechanism was able to follow a predetermined path.

REFERENCES

- [1] S. Asthana, P. Singh, P. Kumaraguru, A. Singh, and V. Naik, “Tring! tring!-an exploration and analysis of interactive voice response systems”, in 4th International Conference on Human Computer Interaction, 2012.
- [2] S. Perugini, T. J. Anderson, and W. F. Moroney, “A study of out-of-turn interaction in menu-based, IVR, voicemail systems”, in Proceedings of the SIGCHI conference on Human factors in computing systems, CHI '07, ACM ,New York, NY, USA, 2007, pp. 961–970.

- [3] Istiadi and E. B. Sulistiarini, "Representing knowledge base into database for WAP and web-based expert system", in International Conference on Information Systems for Business Competitiveness (ICISBC 2013), Semarang, 2013.
- [4] M. Soujanya and S. Kumar, "Personalized IVR system in contact center", In International Conference On Electronics and Information Engineering (ICEIE), Vol. 1, pp. V1-453, August, 2010.
- [5] S. Asthana, P. Singh, and A. Singh, "A usability study of adaptive interfaces for interactive voice response system", in Proceedings of the 3rd ACM Symposium on Computing for Development , ACM, January, 2013.
- [6] R. Karademir and E. Heves, "Dynamic interactive voice response (IVR) platform", In EUROCON 2013 , IEEE, July, 2013, pp. 98-104
- [7] W. H. O., Dengue Guidelines for diagnosis, treatment, prevention and control Geneva: World Health Organization, 2009.