

DEMAND SIDE MANAGEMENT IN SMART GRID USING FUZZY OPTIMIZATION

Mr.A.Mohanraj¹, Mr.V.Naveen kumar², Mrs.G.Muthuselvi³, Mr.M.Sudhakaran⁴, Mr.B.Saravanan⁵
UG Student, Dept. of EEE, GanadipathyTulis's Jain Engineering College, Vellore, India^{1,2}
Assistant professor, Dept. of EEE, GanadipathyTulis's Jain Engineering College, Vellore, India³
Associate professor, Dept. of EEE, GanadipathyTulis's Jain Engineering College, Vellore, India⁴
Associate professor, School of Electrical Engineering VIT University Vellore, India⁵

ABSTRACT

Demand side management (DSM) is one of the important functions in a smart grid that allows customers to make informed decisions regarding their energy consumption, and helps the energy providers reduce the peak load demand and reshape the load profile. This results in increased sustainability of the smart grid, as well as reduced overall operational cost and carbon emission levels.

In the demand side management system basically two types of loads. They are.

1. Base load.
2. Peak load.

Base load is the minimum level of electricity demand required over a period of 24 hours. Example for base is refrigerator. And the example for peak loads are microwave oven may be used for a few minutes, A television or computer may be used for a few hours Lighting in the house is only required during the evening and so on.

Index Terms: Demand side management, distributed energy resource, fuzzy optimization, generation scheduling, load shifting, smart grid.

1. INTRODUCTION

Energy demand management, also known as demand-side management (DSM) or demand-side response (DSR), is the modification of consumer demand for energy through various methods such as financial incentives and behavioral change through education. Usually, the goal of demand side management is to encourage the consumer to use less energy during peak hours, or to move the time of energy use to off-peak times such as nighttime and weekends. Peak demand management does not necessarily decrease total energy consumption, but could be expected to reduce the need for investments in networks and/or power plants for meeting peak demands. An example is the use of energy storage units to store energy during off-peak hours and discharge them during peak hours. A newer application for DSM is to aid grid operators in balancing intermittent generation from wind and solar units, particularly when the timing and magnitude of energy demand does not coincide with the renewable generation.

Electricity use can vary dramatically on short and medium time frames, largely dependent on weather patterns. Generally the wholesale electricity system adjusts to changing demand by dispatching additional or less generation. However, during peak periods, the additional generation is usually supplied by less efficient ("peaking") sources. Unfortunately, the instantaneous financial and environmental cost of using these "peaking" sources is not necessarily reflected in the retail pricing system. In addition, the ability or willingness of electricity consumers to adjust to price signals by altering demand (elasticity of demand) may be low, particularly over short time frames. In many markets, consumers (particularly retail customers) do not face real-time pricing at all, but pay rates based on average annual costs or other constructed prices.

Energy demand management activities attempt to bring the electricity demand and supply closer to a perceived optimum, and help give electricity end users benefits for reducing their demand. In the modern system, the integrated approach to demand side management is becoming increasingly common. IDSM automatically sends signals to end-use systems to shed load depending on system conditions. This allows for very precise tuning of demand to ensure that it matches supply at all times, reduces capital expenditures for the utility. Critical system conditions could be peak times, or in areas with levels of variable renewable energy, during times when demand must be adjusted upward to avoid over generation or downward helping with ramping needs.

In general, adjustments to demand can occur in various ways: through responses to price signals, such as permanent differential rates for evening and day times or occasional highly priced usage days, behavioral changes achieved through home area networks, automated controls such as with remotely controlled air-conditioners, or with permanent load adjustments with energy efficient appliances.

SMART GRID represents a vision of the future power systems integrating advanced sensing technologies, control methodologies and communication technologies at transmission and distribution levels in order to supply electricity in a smart and user friendly way. According to the U.S. Department of Energy's modern grid initiative report, the main characteristics of a smart grid are consumer friendliness, hack proof self-healing, resistance for attack, ability to accommodate all types of generation and storage options, electricity market based efficient operation, high power quality, and optimal assets. This modern grid is prompted by several economical, political, environmental, social, and technical factors.

Demand side management is an important function in energy management of the future smart grid, which provides support towards smart grid functionalities in various areas such as electricity market control and management, infrastructure construction, and management of decentralized energy resources and electric vehicles. Controlling and influencing energy demand can reduce the overall peak load demand, reshape the demand profile, and increase the grid sustainability by reducing the overall cost and carbon emission levels. Efficient demand side management can potentially avoid the construction of an under-utilized electrical infrastructure in terms of generation capacity, transmission lines and distribution Networks.

Smart pricing is a unique characteristic of smart grid made possible by usage of smart metering devices in the automatic metering infrastructure. It could lead to cost-reflective pricing based on the entire supply chain of delivering electricity at a certain location, quantity and period. When smart pricing is used

with demand side management, control of the customer's energy usage will be influenced by real-time penalty and incentive schemes at all levels of the supply chain. However, the rationale behind the implementation of demand side management within the context of the smart grid is to promote the overall system efficiency, security and sustainability by maximizing the capacity of the existing infrastructure while facilitating the integration of low carbon technology into the system. Demand side management also plays a significant role in electricity markets.

Demand side management system will inform cluster's central controller about new load schedule and available load reduction capabilities for each time step of next day. Then, the central controller can place bids in the market such that some loads from the peak demand will be shifted. Profits made through this load demand side management will be reimbursed to customers of the cluster. There are several demand side management techniques and algorithms used in the literature .

Most of them are system specific strategies, and some of which are not applicable to practical systems that have a wide variety of independent devices. Most of the techniques were developed using dynamic programming and linear programming. These programming techniques cannot handle a large number of controllable devices from several types of devices which have several computation patterns and heuristics.

The primary objective of the demand side management techniques presented in the literature is reduction of system peak load demand and operational cost. Although the utilities are capable of offering different incentives to respective customers for direct control over selected loads by grouping the customers' loads, most of the methodologies used in the literature do not consider the criteria and objectives independently.

Thus, it is difficult to employ these methods for demand side management of future smart grids which aim to provide the customers with greater control over their energy consumption. In a smart grid, the demand side management strategies need to handle a large number of controllable loads of several types. Furthermore, loads can have characteristics which spread over a few hours. Therefore, the strategies should be able to deal with all possible control durations of a variety of controllable loads.

In addition, the transformation of today's grid towards smart grid opens new perspectives on demand side management. First, a significant part of the generation in smart grid is expected to come from renewable energy resources such as wind and solar . The unpredictability of these renewable energy sources makes power dispatch functions in a smart grid challenging. Such a scenario necessitates the use of load control methodologies. Next, the operation of smart grid requires a two way communication between central controller and various system elements.

2. PROPOSED SYSTEM

There are specific components characteristic of a fuzzy controller to support a design procedure. Figure 4.6 shows the controller between the preprocessing block and post processing block

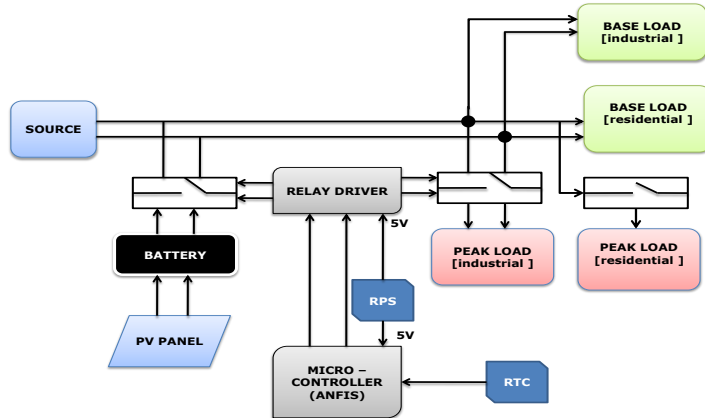

Structure of Fuzzy Logic

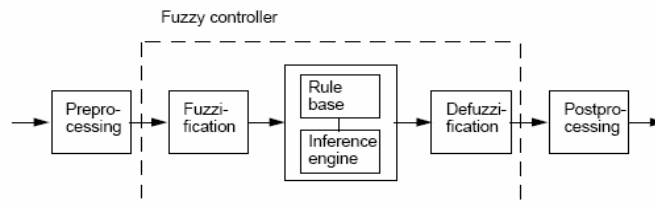

3. HARDWARE IMPLEMENTATION

A. CIRCUIT DIAGRAM

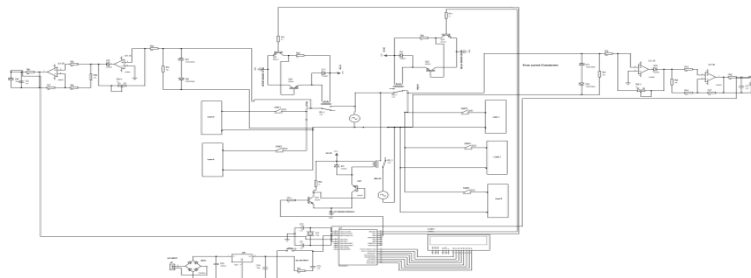

Circuit diagram

The devices subjected to control in the residential area have small power consumption ratings and short durations of operation. Table II shows device types that are subjected to load control and their consumption patterns. There are over 2600 controllable devices available in this area from 14 different types of devices.

4. SIMULATION RESULT

RESIDENTIAL LOAD

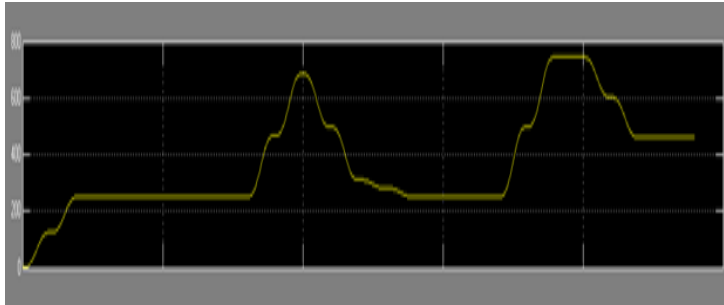

TRIP RELAY SIGNAL

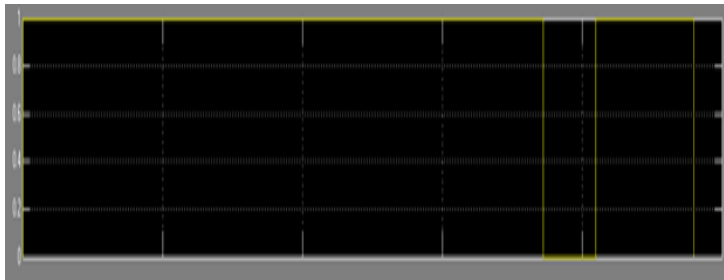

INDUSTRIAL LOAD

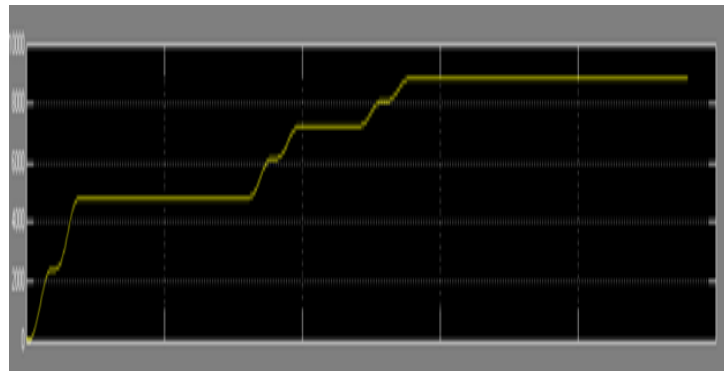

TRIP SIGNAL

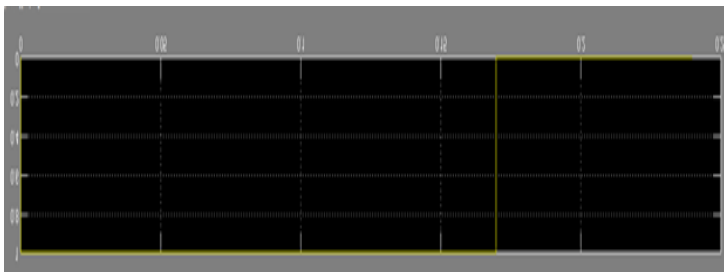

B.HARDWARE KIT

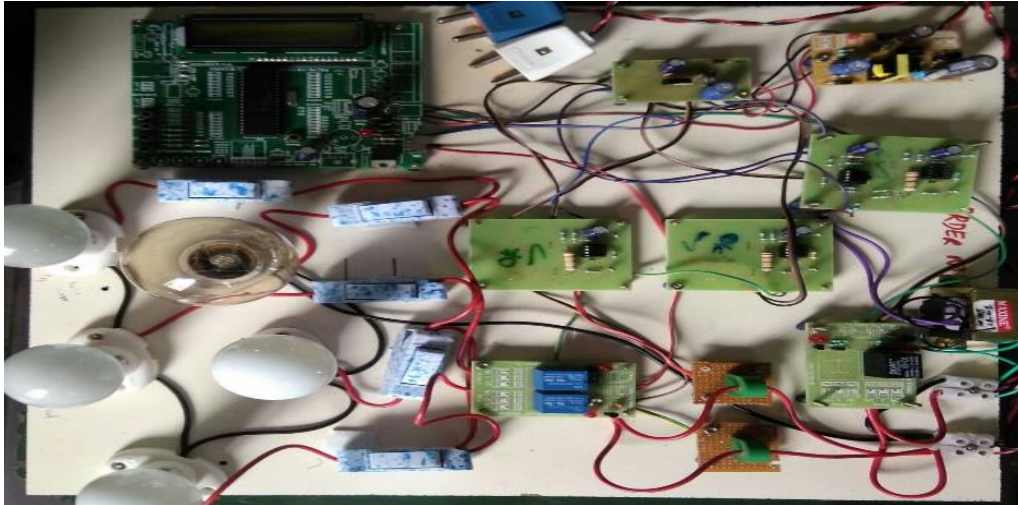

CONCLUSION

Demand side management has potential to provide many benefits to the entire smart grid, particularly at distribution network level. This project presents a demand side management strategy that can be employed in the future smart grid. A heuristic based evolutionary algorithm is developed for solving the problem. Simulations were carried out on a smart grid which contains two different kinds of customers' areas. The simulation outcomes show that the proposed algorithm is able to handle a large number of controllable devices of several types, and achieves substantial savings while reducing the peak load demand of the smart grid.

REFERENCES

1. Rahman, S. "An efficient load model for analyzing demand side management impacts." *IEEE Transactions on Power Systems* 8, no. 3 (1993): 1219-1226
2. Cohen, Arthur I., and Connie C. Wang. "An optimization method for load management scheduling." *IEEE Transactions on Power Systems* 3, no. 2 (1988): 612-618.
3. Popovic, Zeljko N., and Dragan S. Popovic. "Direct load control as a market-based program in deregulated power industries." In *Power Tech Conference Proceedings, 2003 IEEE Bologna*, vol. 3, pp. 4-pp. IEEE, 2003.
4. Yao, Lechter, Wen-Chi Chang, and Rong-Liang Yen. "An iterative deepening genetic algorithm for scheduling of direct load control." *IEEE Transactions on Power Systems* 20, no. 3 (2005): 1414-1421

5. Kah-Hoe Ng Gerald B Sheblt Student Member Senior Member Department of Electrical and Computer Engineering Iowa State University Ames."DIRECT LOAD CONTROL - A PROFIT-BASED LOAD MANAGEMENT USING LINEAR PROGRAMMING" IA 5001 1 IEEE Transactions on Power Systems, Vol. 13, No. 2, May 1998
6. Yuan-Yih Hsu, Senior Member Chung-Ching Su Department of Electrical Engineering National Taiwan University Taipei,"DISPATCH OF DIRECT LOAD CONTROL USING DYNAMIC PROGRAMMING"Taiwan Transactions on Power Systems, Vol. 6, No. 3, August 1991
7. G. Heber Weller, m, Member IEEE Florida Power Corporation 3201 - 34 Street, South St. Petersburg, Florida 3371 1"MANAGING THE INSTANTANEOUS LOAD SHAPE IMPACTS CAUSED BY THE OPERATION OF A LARGE-SCALE DIRECT LOAD CONTROL SYSTEM" IEEE Transactions on Power Systems, Vol. 3, No. 1, February 1988
8. Zeljko N. Popovic, and Dragan S. Popovic, Member, IEEE "A Linear Programming Model for Reducing System Peak Through Customer Load Control Programs"
9. C. N. Kurucz D. Brandt S. Sim Department of Management Science Commercial Industrial Marketing Integrated Resource Planning University of Miami Coral Gables, FL 33 124 USA Florida Power and Light Company Miami, FL 33 102 USA Florida Power and Light Company Miami, FL 331102 USA
10. Kah-Hoe Ng Gerald B Sheblt Student Member Senior Member Department of Electrical and Computer Engineering Iowa State University Ames. IA 5001 "DIRECT LOAD CONTROL - A PROFIT-BASED LOAD MANAGEMENT USING LINEAR PROGRAMMING" IEEE Transactions on Power Systems, Vol. 13, No. 2, May 1998

AUTHOR'S PROFILE

Mr.A.Mohanraj has received his B.E degree (Electrical and Electronics engineering) in 2017 from Ganadipathy Tulsi's Jain Engineering College, Anna university, Chennai, India

Mr.V.Naveen Kumar received his B.E degree (Electrical and Electronics Engineering) in 2017 from Ganadipathy Tulsi's Jain Engineering College, Anna University, Chennai, India

Mrs.G.Muthuselvi. *Assistant professor, Dept. of EEE, GanadipathyTulis's Jain Engineering College, Vellore, India*