

A single stage ccm zeta micro inverter for solar photovoltaic AC module

¹Nasari Mahesh Babu, PG Scholar , Power Electronics And Drives, Kottam Karunakara Reddy Institute Of Technology, Kurnool Andhra Pradesh.

²J.Nagarjuna Babu, Assistant Professor, Dept of EEE, Kottam Karunakara Reddy Institute Of Technology, Kurnool Andhra Pradesh.

³D.V.Srihari Babu HOD Dept of EEE, , Kottam Karunakara Reddy Institute Of Technology, Kurnool Andhra Pradesh.

Abstract:

Renewable sources of energy are becoming more popular due to environmental concerns and need for energy. Solar energy is one of the most extensively exploited sources of effective natural energy. Microinverters are low power DC-AC converters that are attached to each solar PV panel of a solar energy system which are mainly based on flyback converter topology. In this paper, a novel single stage zeta microinverter is proposed. Zero Voltage Switching (ZVS) technique is implemented for this topology with the help of simple snubber circuit with a few passive elements and variable frequency control technique. An increment in the output voltage and reduction in the switching losses can be achieved by the implementation of Artificial Neural Networks (ANN) based controller for the closed loop control. High voltage gain is achieved by the modified inverter and thus making the low power inverter suitable for the utilization of PV applications. By the implementation of artificial intelligence based Maximum Power Point Tracking (MPPT) control technique, the Maximum Power Point (MPP) will be extracted within a reduced tracking time. Thus modified system acts as an effective interface between PV system and the AC grid.

Keywords: Microinverter, Maximum power point tracking, Artificial neural network, Fuzzy logic.

1. INTRODUCTION

The global electrical energy consumption is ever growing particularly since the last few decades. This trend is expected to grow further in the future. The reserve of conventional energy sources is not sufficient to satisfy the steady increase in the energy demand. Consumption of these non-renewable energy sources leads to an increase in pollution by the emission of the greenhouse gases. Thus renewable energy gained importance. Among the various renewable resources of energy, the solar energy systems based on PV cells is the most popular source. The solar energy is clean, free from pollution, available in abundance and above all it is available to all at fairly equal manner unlike fossil fuels. It has high energy density compared to its counterparts India is a tropical country and hence solar PV power system is one of the most promising sources of power in the years to come. However, the investment cost of solar PV system is high. This high cost is mainly due to the components of the system. A PV system generally consists of a PV array, a power conditioner and a battery. Power conditioner mainly include a DC-DC converter which is followed by an

inverter. The necessary isolation should be provided between input and output of the system. PV modules generate DC which is then converted to AC by a conventional voltage source converter to connect PV modules to AC utility grid line. The latest technology is Photovoltaic AC Module (PV ACM) also named as microinverter. It is a compact and modular structure for low power PV system applications. In short these are low power inverters in the range 100-350 W. In this paper, the main focus is given to the MPPT control method and the control of the converter when connected to a grid. The MPPT algorithm employed to the PV module is based on the fuzzy logic. The control of the microinverter is obtained with the help of ANN, one of the artificial intelligence technique. A nondissipative snubber circuit with passive electrical elements is implemented in the primary side of the zeta microinverter. In this paper, a novel zeta microinverter with a passive snubber is proposed. Zeta converter can achieve higher bandwidth and good closed loop stability compared to flyback topologies.

2. RELATED WORK

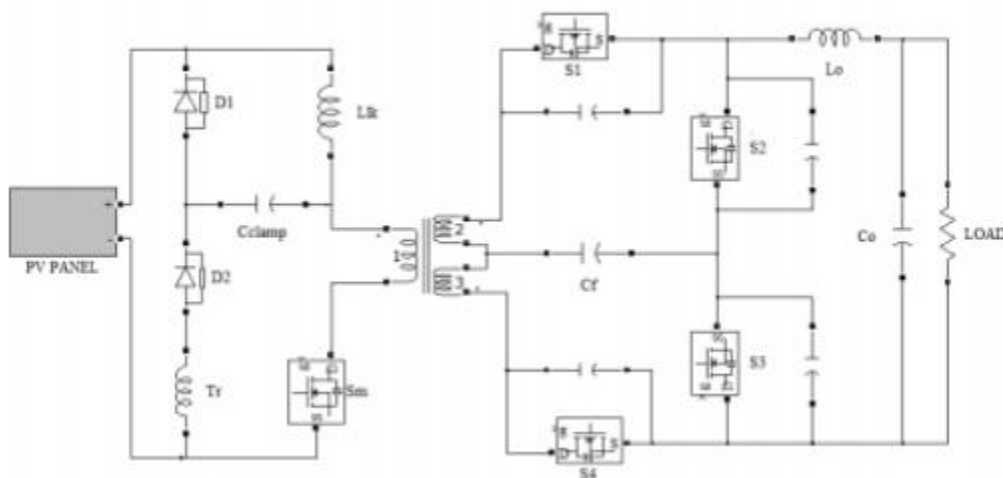

Fig.1. Structure

The main switch S_m , is operated at high frequency with a variable duty cycle to produce the appropriate AC output voltage waveform. In order to ensure an AC output wave synchronized with grid, the switches on the secondary side are turned on and off in an appropriate alternate manner. For positive polarity of the energy delivered at the AC output S_1 and S_3 are turned on and S_2 and S_4 are kept off. Switches, S_2 and S_4 are gated to conduct and switches S_1 and S_3 are turned off, if the polarity required is negative. Due to rotation of earth and non-linear characteristics between PV panel current and voltage, the PV system has low conversion efficiency. The output current of the PV module is directly proportional to the solar irradiance whereas the temperature and the output voltage are inversely proportional. Thus the output power of the PV system increases with the increase in solar irradiance and decreases with increase in temperature. To obtain the maximum efficiency from a PV system, it must be operated at an equilibrium point. This point of equilibrium is commonly known as Maximum Power Point (MPP). For transferring maximum

power, the module must be operated at a' , b' , c' instead of a , b , c . MPPT is employed to regulate the actual operation voltage of the PV panel to the voltage at MPP. This is achieved by changing the duty cycle of the converter connected to the PV system. During years, many MPPT techniques have been developed and implemented such as Perturb and Observe (P&O), Incremental Conductance, constant voltage method, fuzzy logic etc. The choice of MPPT method mainly depends on its complexity and the time taken to track the MPP.

3. PROPOSED SYSTEM

Nowadays ANN has been strongly developed both in theory and in applications. It is a machine learning approach which is a simplified model of biological nervous system. The motivation for such a concept was from the way a human brain performs the computations.

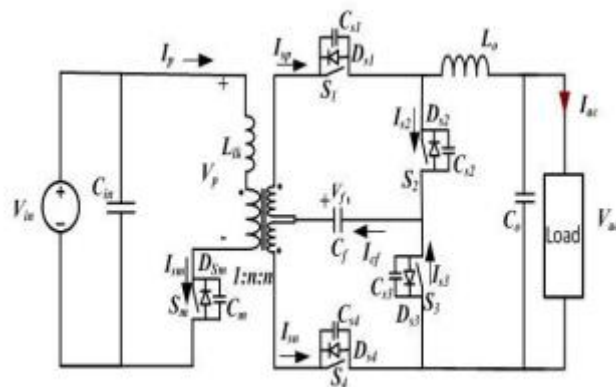

Fig.2.Zeta Converter

By using ANN, artificial intelligence problems can be solved without creating a model of a real dynamic system. ANN involves a highly interconnected network of a large number of small processing elements called neurons. A common structure of AN. These have the ability to learn and adapt under noise and uncertainty. The connections between the neurons determine the complex global behavior exhibited by them. Artificial neuron receives a number of inputs and has only one output. In ANN, artificial neurons are organized in layers namely input layer, hidden layer and output layer. The network receives the inputs by neurons in the input layer. The input layer communicates to one or more hidden layers which then link to an output layer. The actual processing is done in the hidden layers by a system of weighted connections to the switches at the secondary side of the transformer. The error signal is generated by comparing the actual output voltage of microinverter with the reference grid voltage. The generated error is compensated using the ANN controller. The Levenberg Marquardt Back Propagation algorithm is used to train the network. By tuning the PI or PID controllers, the data set which are used to train the ANN by various algorithm can be obtained. The proposed system was simulated in MATLAB/Simulink software. MATLAB (matrix laboratory) is a multi- paradigmnumerical computing environment and fourth-generation programming language. A proprietary programming language developed by MathWorks.

4. ANALYSIS

MATLAB allows matrix manipulations, plotting of functions and data implementation of algorithms, creation of user interfaces and interfacing with programs written in other languages, including C, C++, Java, Fortran and Python. The converter was implemented with input voltage in the range 40-50V and the grid reference voltage was considered to be 110V. to the isolated zeta converter.

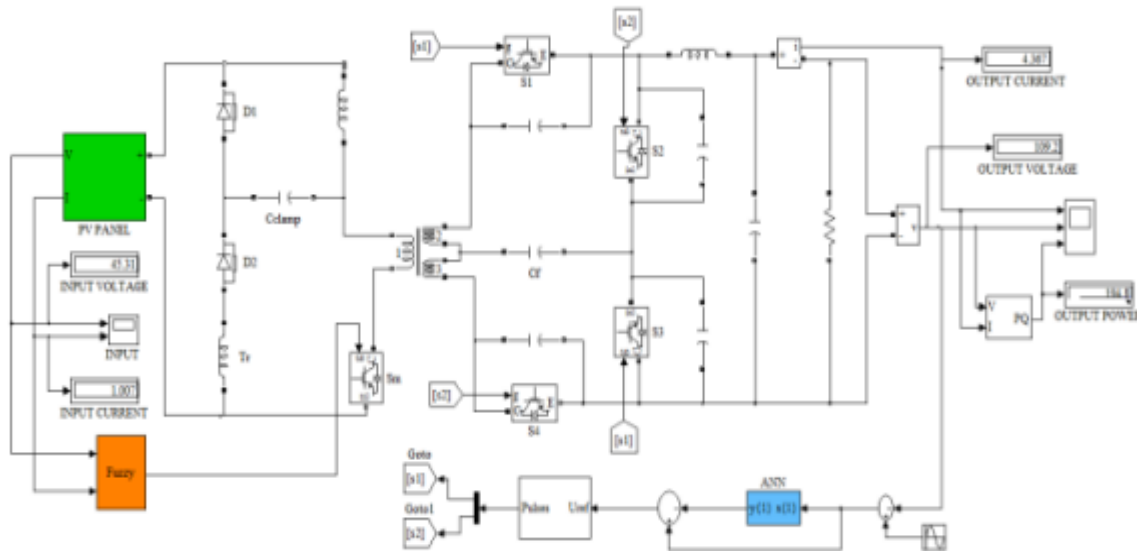

Fig.3.Output Simulink

The converter is used to convert the power from DC to AC. The control circuit consists of Opto coupler, Gate driver and Buffer. The programmable interface controller is act as a microcontroller. The output of the zeta converter is given to the single phase inverter. In order to fed to the grid it is inverted and the output of the inverter is filtered by using LC filter. So the harmonics of the inverter will be reduced. The AC output is given to the grid. The efficiency of the system will be improved because of the micro inverter operating at continuous conduction mode. So the switching losses will be reduced. However, for a practical design with higher flying capacitance value, corresponding increase in series resistance of capacitor will increase conduction losses. Although, conduction losses in the diode will reduce with increasing capacitance value. Microinverter at 20kHz theoretical loss distributions for zeta microinverter in CCM and DCM modes respectively, at different load conditions. It should be observed that at any load conditions the losses in CCM zeta microinverter are lower than DCM. A single stage CCM zeta micro inverter has been proposed for solar PVAC module. Steady-state operation and analysis of proposed zeta micro inverter in both DCM and CCM has been studied. Micro inverter operation in CCM mode results in reduced conduction losses, switch ratings and current stress. The proposed inverter provides HF isolation and has only a single switch operating at HF which will reduce the switching losses. The circuit is simple and easy to develop. Critical factors to consider while designing the inverter have been discussed and studied. A 220 W inverter prototype has been developed and tested in the laboratory to validate the claims, proposed operation and design. The laboratory prototype has a peak efficiency of 93% at rated power of 220 W.

CONCLUSION

A PV system with fuzzy logic based MPPT fed single stage zeta microinverter with ANN controller is proposed. The proposed converter has a snubber circuit with passive electrical elements. The proposed microinverter considered has only one switch being operated at high frequency which results in low switching losses. Soft switching is implemented which further reduces the losses especially turn-off losses. The flyback high frequency transformer not only boosts the voltage obtained from the PV panel but also provides isolation.

REFERENCES

- [1] Lallu Mol K Johny and Muhammedali Shafeeque K, "PV Fed Flyback DC-AC Inverter with MPPT Control", International Conference on Magnetics, Machines & Drives (AICERA-2014 iCMMD), Kottayam, pp. 1-6, 2014
- [2] Aniruddha Mukherjee, Majid Pahlevaninezhad and Gerry Moschopoulos, "A Novel ZVS Resonant Type Flyback Microinverter with Regenerative Snubber", 29th Annual IEEE Applied Power Electronics Conference and Exposition (APEC), Fort Worth, pp. 2958-2964, 2014
- [3] Quan Li and Peter Wolfs, "Recent Developments in the Topologies for Photovoltaic Module Integrated Converters", 37th IEEE Power Electronics Specialists Conference (PESC'06), Jeju, pp. 1-8, 2006
- [4] Ravi K Surapaneni and Akshay K Rathore, "A Single Stage CCM Zeta Microinverter for Solar Photovoltaic AC Module", IEEE Journal of Emerging and Selected Topics in Power Electronics, vol. 3, no. 4, pp. 892-900, 2015
- [5] N. Kasa, T. Iida and A. K. S. Bhat, "Zero-Voltage Transition Flyback Inverter for Small Scale Photovoltaic Power System", 36th IEEE Power Electronics Specialists Conference (PESC'05), Recife, pp. 2098-2103, 2005
- [6] Haitham Hassan, Mostafa Abel Geliel and Mahmoud Abu-Zeid, "A Proposed Fuzzy Controller for MPPT of a Photovoltaic System", IEEE Conference on Energy Conversion (CENCON), Johor Bahru, pp. 164-169, 2014.